

Integrated Optical Ti:LiNbO₃ Ring Resonator for Rotation Rate Sensing

C. Vannahme, H. Suche, S. Reza, R. Ricken, V. Quiring, and W. Sohler

Angewandte Physik, Universität Paderborn, Warburger Str. 100, 33098 Paderborn, Germany
email: sol_cv@physik.uni-paderborn.de

Abstract: Design, fabrication, packaging, and characterization of a high finesse Ti:LiNbO₃ integrated optical ring resonator are reported. First results of rotation rate sensing are presented.

Introduction

Optical rotation rate sensors utilizing the Sagnac effect are attractive devices, which - in contrast to their mechanical counterparts - have no moving parts [1]. Active ring laser gyroscopes and passive fiberoptic gyroscopes of high resolution are already used successfully for navigation of aircrafts and ships. However, for consumer needs with low and medium resolution like in car navigation and robotics, less complex and cheaper sensors systems are needed suited for volume production. Integrated optical ring resonators based on planar microfabrication technologies have the required potential. If fabricated on an electrooptic substrate like LiNbO₃ (LN), even optical signal processing components can be monolithically integrated. In contrast to ring resonators for wavelength filtering, devices for rotation rate sensing must have a much larger diameter as the Sagnac effect is proportional to the area enclosed by the ring.

Up to now, only a few integrated optical ring resonators have been reported for rotation rate sensing. They have been fabricated by chemical vapour deposition of silica on silicon [2-4].

In this paper we report the design, fabrication, packaging, and characterization of the first ring resonator fabricated in LN for rotation rate sensing with a diameter of 60 mm.

Theoretical modelling and design

The overall waveguide structure to be investigated is shown in Fig. 1. It consists of a single mode (at $\lambda \sim 1550$ nm), Ti:LN ring resonator of 60 mm diameter.

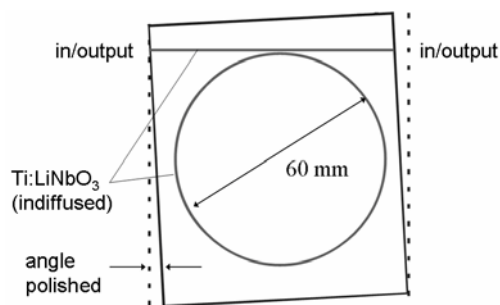

Fig. 1: Scheme of the integrated ring resonator connected with an adjacent straight waveguide via a directional coupler.

Light can be coupled to the ring via a directional coupler connecting a straight waveguide and the resonator.

The directional coupler determines to a large degree the properties of the resonator and – as a consequence – the properties of the rotation rate sensor. It is formed by the straight and the curved waveguides approaching each other. As the Ti:LN waveguides are anisotropic with polarization dependent mode field dimensions also the properties of the directional coupler will be polarization dependent. Nevertheless, we will consider in the following the TE-polarization only as the corresponding waveguide losses are smaller than those of the TM-mode. Therefore, for a given polarization (and wavelength) there is only one parameter to be adjusted, namely the smallest gap d between both guides (see Fig. 2).

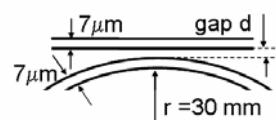

Fig. 2: Directional coupler formed by straight and curved channel guides.

In a first step a power coupling coefficient K is calculated as function of d at the wavelength $\lambda = 1550$ nm (see Fig. 3 on the left). K is equivalent to the reflectivity of one of the two mirrors of a conventional Fabry-Perot cavity with a second mirror of reflectivity 1. Moreover, the dependence of K on the wavelength is analyzed and presented on the right of Fig. 3 for $d = 4.9$ μm as fixed parameter. This result shows that the coupling can be fine tuned even after fabrication by selecting the right wavelength.

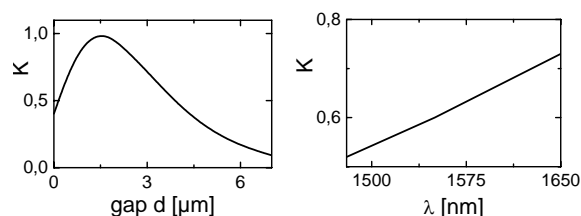

Fig. 3: Left: power coupling coefficient K as function of the minimum gap d of the directional coupler at $\lambda = 1550$ nm. Right: K versus wavelength for $d = 4.9$ μm .

Knowing the power coupling coefficient K the resonances of the ring cavity can be modelled using waveguide propagation losses α of 0.03 dB/cm as measured in straight channel guides for TE-polarization.

Bending losses can be neglected for a radius of curvature larger than about 25 mm. Fig. 4 shows two resonances of the transmission through the straight guide versus the optical frequency change. The free spectral range of the ring cavity is 830 MHz with a halfwidth of the resonances of 80 MHz. The diagram allows a direct comparison with experimental results (see Fig. 9). An equivalent representation is the transmission versus phase, which is used to analyze the rotation rate sensitivity.

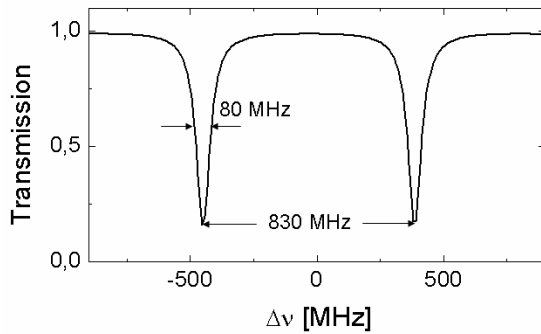

Fig. 4: Calculated straight waveguide transmission (see Fig. 1) versus a change $\Delta\nu$ of the optical frequency for $\alpha = 0.03$ dB/cm and $K = 0.3$.

To determine the optimum gap d_{opt} of the directional coupler (for $\lambda = 1550$ nm) the steepest slope of the ring resonances is calculated as function of the power coupling coefficient K and as function of the propagation loss coefficient α . The steepest slope determines the operation point of maximum sensitivity for rotation rate sensing. The results are presented in Fig. 5 yielding an optimum K of about 0.3 nearly independent on the waveguide losses. As a consequence, the optimum gap should be $d_{opt} = 4.9$ μm (see Fig. 3).

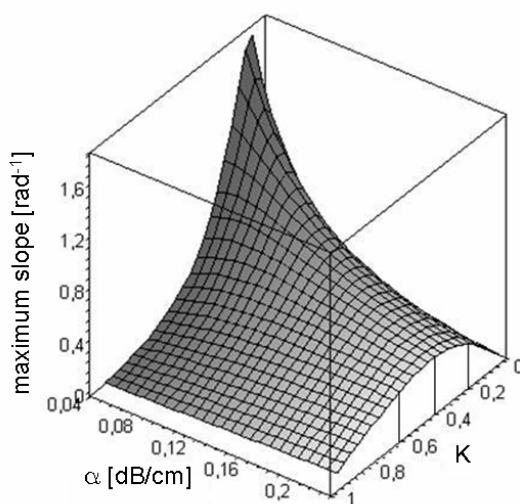

Fig. 5: Steepest slope of the ring resonances as function of the waveguide propagation losses α and of the power coupling coefficient K of the directional coupler.

The ultimate sensitivity of the integrated ring resonator operated as optical gyroscope is determined by the quantum noise limit. The minimum rotation rate is given by [1]:

$$\Omega_{\min} \approx \frac{\lambda_0}{2R} \frac{\Gamma}{\sqrt{n_{\text{ph}} \eta_D \tau}}$$

with R : ring radius; λ_0 : vacuum wavelength; Γ : halfwidth of the cavity resonance; n_{ph} : number of photons/sec; η_D : quantum efficiency of the photodiode; τ : averaging time.

Using the parameters of our sample ($R = 3$ cm; $\tau = 1$ s; $\eta_D = 0,5$; $\lambda_0 = 1550$ nm; $\Gamma = 80$ MHz; $n_{\text{ph}} = 8 \cdot 10^{15} \text{s}^{-1}$) a minimum rotation rate of

$$\Omega_{\min} = 6,7^\circ / \text{h} = 0,45 \Omega_E$$

can be expected; Ω_E is the angular velocity of the earth.

Sample fabrication and experimental setup

According to the modelling results a sample has been designed and fabricated in a Z-cut LN substrate of 75 mm x 75 mm dimensions. By an indiffusion (1060 °C; 8.5 hrs) of photolithographically defined 7 μm wide, 100 nm thick Ti-stripes the waveguide structure has been formed with a ring cavity of 60 mm diameter and a minimum gap width of the directional coupler of 4.9 μm (see Fig. 1). The two end faces of the straight waveguide have been angle polished to avoid back reflections. Afterwards, the sample has been pigtailed with polarization maintaining fibers and glued on a copper base plate on a thermoelectric cooler/heater to enable temperature stabilization. Finally, it has been mounted in a rotatable aluminium box (see Fig. 6).

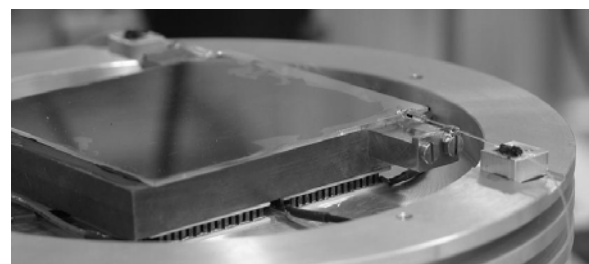

Fig. 6: Opened aluminum box with pigtailed ring resonator on a copper base plate, which can be temperature stabilized by a thermoelectric cooler/heater.

The packaged ring resonator is driven via an eccentric as shown in Fig. 7; it can be rotated back and forth with a time dependent rotation rate. Depending on the speed of the driving electric motor the amplitude of the angular velocity of the sample can be adjusted up to about 3 rad/sec.

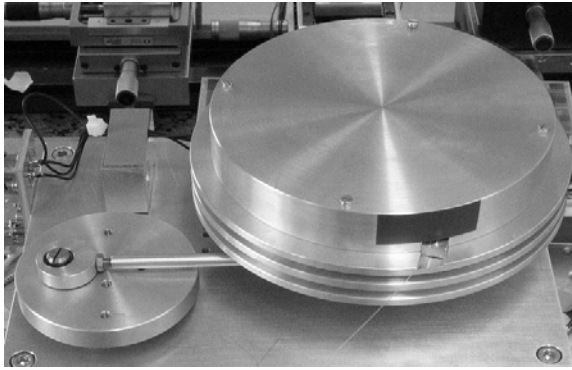

Fig. 7: Electromechanical drive to rotate the packaged ring resonator.

The experimental setup to investigate the resonator and to study the Sagnac effect is shown in Fig. 8. A semiconductor extended cavity laser (ECL) is used as tunable coherent source of about 150 kHz instantaneous linewidth in the wavelength range around 1550 nm; it can be frequency modulated by an external function generator. The light is coupled to a standard single mode fiber and routed via 3 dB coupler, polarization controller and circulator either to one or to both inputs of the sample to allow an uni- (solid lines) or bidirectional (solid and dotted lines) mode of operation. The transmitted light is routed via the circulator(s) to the photodiode(s). Their signals are processed by lock-in amplifiers to allow laser frequency control and measurement of the rotation rate.

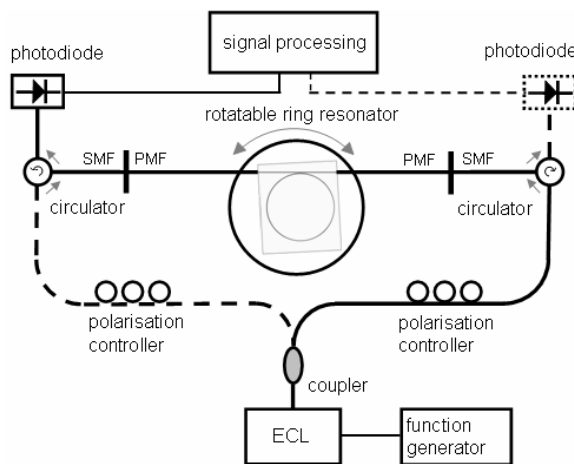

Fig. 8: Experimental setup to investigate the ring resonator and to study the Sagnac effect in uni- or bidirectional (dotted) operation. ECL: tunable extended cavity laser. PMF: polarization maintaining fiber. SMF: single-mode fiber

In the unidirectional mode the transmission resonances can be measured either for clockwise or counterclockwise propagating light. In the bidirectional mode of operation both resonances can be measured simultaneously.

To observe the Sagnac-effect and to measure a rotation rate in the unidirectional mode of operation the laser frequency is periodically modulated around a

cavity resonance (transmission minimum). The amplitude of this sinusoidal modulation of frequency Ω should correspond to about half of the halfwidth of the resonance (i. e. about 40 MHz for the modelling example presented in Fig. 4). As result the detector signal consists of even multiples of the modulation frequency only. If the Sagnac effect shifts the resonance also odd multiples arise and the first harmonic can be detected with the help of the lock-in amplifier. However, this mode of operation requires a stabilized ring resonator and a laser center frequency stabilized to a ring resonance (at zero rotation rate). All drift effects and resulting phase shifts, which are not caused by the Sagnac effect, give rise to a signal at the first harmonic as well. Therefore, the bidirectional mode of operation is preferable. As result the difference of the two photodiode signals is proportional to the rotation rate. Only phase shifts caused by the Sagnac effect change the differential signal; reciprocal phase shifts will be eliminated automatically as long as the laser frequency is close to the point of operation at the steepest slope of the resonance.

Experimental results and discussion

Fig. 9 shows both, the clockwise and counterclockwise resonances measured simultaneously using the bidirectional setup (see Fig. 8). According to the ring parameters the free spectral range is 830 MHz. The halfwidth and depth of the cavity resonances are 85 MHz and 92%, respectively, in excellent agreement with the modelling results (see Fig. 4). The resulting finesse of the resonator is 10 corresponding to a Q of $2.4 \cdot 10^6$. Some small oscillations can be observed mainly for ccw propagation in the bidirectional mode

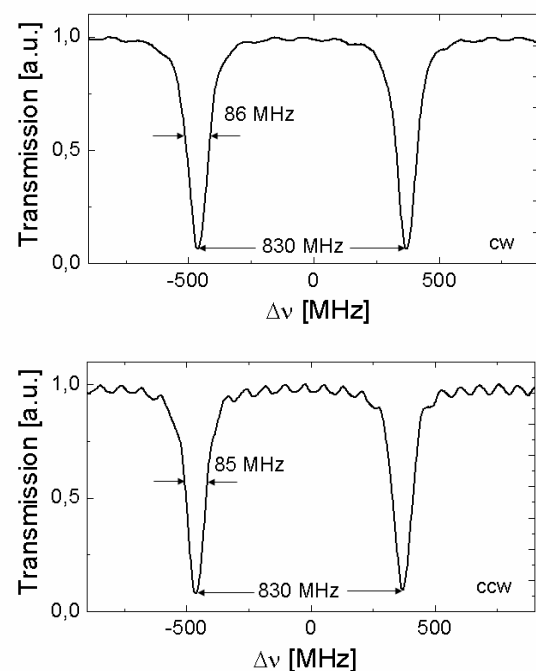

Fig. 9: Cw and ccw resonance curves of a ring resonator in bidirectional operation.

of operation only. They are due to interference effects caused by unidentified residual reflections at fiber connectors.

Unfortunately, due to instabilities of the laser frequency it was not yet possible to unambiguously measure the Sagnac effect and in this way the rotation rate using the method sketched above for bidirectional operation. Only for unidirectional operation, an output signal of the lock-in amplifier could be observed proportional to the rotation rate of the sample as a whole. In Fig. 10 the angular position of the sample is plotted versus time; therefore, its first derivative is the time dependent rotation rate. Though the amplitude of the lock-in amplifier output is not stable due to a drift of the laser frequency the signal shows the expected behaviour. From the experimental results a minimum rotation rate of $\Omega_{\min} = 10 \text{ }^\circ/\text{s}$ can be derived more than three orders of magnitude larger than the theoretically expected minimum rate.

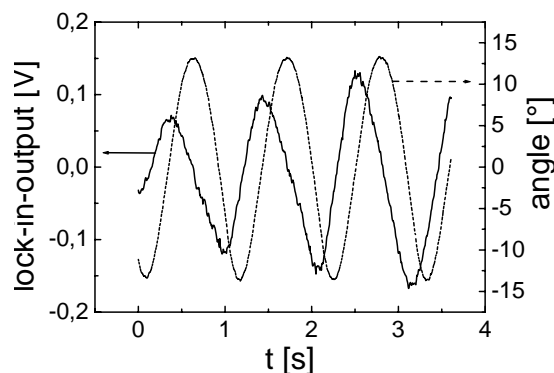

Fig. 10: Angular position of the ring resonator (right ordinate) and output signal of the lock-in amplifier (left ordinate) versus time. 0.1 V correspond to a rotation rate of about $100 \text{ }^\circ/\text{s}$.

Conclusions

We have reported the first successful demonstration of the Sagnac effect in a Ti:LiNbO_3 waveguide ring resonator of 60 mm diameter and a Q of $2.4 \cdot 10^6$. The ring cavity has been designed to yield the steepest slope of the transmission at the turning point of a cavity resonance. By dithering the laser frequency and using a lock-in technique the non-reciprocal Sagnac shift of a resonance as function of the rotation rate has been demonstrated. Drift effects of the mean laser frequency with respect to the ring resonance did not yet allow a stable measurement of better accuracy.

In the future, a slow feedback loop will be introduced to lock the laser frequency to a ring resonance. Moreover, an advanced lock-in technique for bidirectional operation of the ring cavity will allow to measure the non-reciprocal resonance frequency splitting separately.

References

- 1 Ezekiel, S., Arditty, H. J.: *Fiber-Optic Rotation Sensors and Related Technologies*, Springer Verlag, Berlin Heidelberg New York, 1982
- 2 Suzuki, K., Takiguchi, K., Hotate, K.: *Monolithically Integrated Resonator Microoptic Gyro on Silica Planar Lightwave Circuit*, J. Lightwave Technol. **18** (1), pp. 66-72, 2000
- 3 Monovoukas, C., Swieki, A. K., Maseeh, F.: *Integrated optical gyroscopes offering low cost, small size and vibration immunity*, Proc. SPIE **3936**, pp. 293-300, 2000
- 4 Ma, H., Zhang, X., Jin, Z., Ding, C.: *Waveguide-type optical passive ring resonator gyro using phase modulation spectroscopy technique*, Opt. Engineering, **45** (8), Article 080506, 2006