

Polarization effects in gradient index MMI structures made by K^+ - Na^+ ion exchange in glass

Damian Kasprzak, Marek Błahut*

Institute of Physics, Silesian University of Technology,
44-100 Gliwice ul. Krzywoustego 2, Poland, *e-mail: mblahut@polsl.pl

Abstract

Experimental results obtained by visualization method of modal interference in MMI gradient structures, using fluorescence of the substance covering the MMI section, are presented. Experimental investigations are carried out for MMI structures made by K^+ - Na^+ ion exchange process in glass. The investigations concern the self-imaging phenomena for symmetrical and paired interference for TE, TM and unpolarized light excitation. The comparisons between results obtained and BPM simulations are presented.

Introduction

Multimode interference (MMI) structures have been for a few years subject to intensive research studies [1]. A large majority of works on MMI concerned interference structures made on the base of step-index waveguides. In 2000 in the paper [2] was proposed for the first the application of MMI in graded-index structures. Gradient structures made by ion exchange in glass are particularly attractive for MMI technology. Ion exchange technique making use of multi-step diffusion processes, electrodiffusion, heating, diffusive and electrodiffusive burying which decide on intermode interference effects to be easily changed. In work [3] is proposed the experimental method which allows visualization of effects of modal interference in MMI structures and some testing results for gradient index MMI structures made by K^+ - Na^+ and Ag^+ - Na^+ ion exchange in glass. The method uses fluorescence of the substance covering the MMI section. In this paper, using this method we show experimental dependence of light propagation on the window width, technological process parameters and the polarization of guided waves for structures made by K^+ - Na^+ ion exchange.

Experimental method

Investigations of MMI structures are carried out in the arrangement described in the paper [3], shown in Fig.2. The MMI section in which the mode field's interference is observed excited from laser by the light of wavelength $\lambda=0.63\mu\text{m}$ is covered with fluorescent substance by spin-coating.

This substance is the Nile Blue "A" perchlorate suspension in PMMA. Fluorescent substance produces lightening proportional to the energy of the excited mode. Recording of successive sequences of mode field interference patterns, by CCD camera on PC, makes it possible to find the propagation lengths for N-fold images.

Presented arrangement allows investigating MMI structures excited by polarized (TE or TM) field from laser through the polarizer and un-polarized field from single-mode fibre.

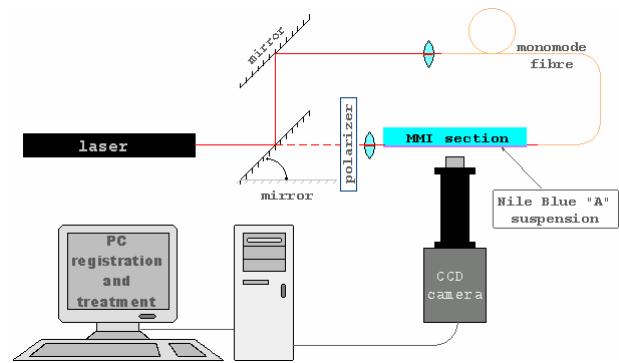

Fig.1 Experimental arrangement

That makes it possible to determine the dependence of propagation lengths for N-fold images on the window width, and the polarization of guided light.

Polarization effects in K^+ - Na^+ ion exchanged waveguides

The investigated MMI sections are produced in the ion exchange process of in the time of 1h and temperature of 400°C in borosilicate glass. Diffusion is performed through the masks opening, in which, depending on the direction of excitation, symmetric or paired interference can be observed [1]. Widths W_M of the masks of MMI sections are 30, 39, 51, 60, 69 and $81\mu\text{m}$.

Experimental results are compared with BPM simulation. The distribution profile of refractive index of MMI section obtained in the diffusion process is calculated numerically from the nonlinear diffusion equation [4].

$$\frac{\partial C_K}{\partial t} = \nabla \left[\frac{D_K}{1 - (1 - m) \cdot C_K} \cdot \nabla C_K \right]$$

where C_K is the dopant K^+ ions concentration, proportional to the refractive index change. Material parameters of the technological process - self-diffusion coefficient of K^+ ions D_K , the mobility ratio m of the ions K^+ and Na^+ , and the maximum of the refractive index change were determined by measurements of respective planar index profiles using IWKB method.

Fig.2 presents distribution profiles of the refractive index for the diffusion process of potassium ions at temperature 400°C and time 165h obtained by IWKB method [4]. The determined self-diffusion coefficient is equal 2.18 $\mu\text{m}^2/\text{h}$ for both profiles; whereas the distribution maxima on the surface are equal respectively 0.0095 and 0.0117. The observed differences in the distribution of the refractive index for both orthogonal polarizations result from the anisotropy of strains taking place during the technological process, and are of significant importance for performance characteristics of the MMI.

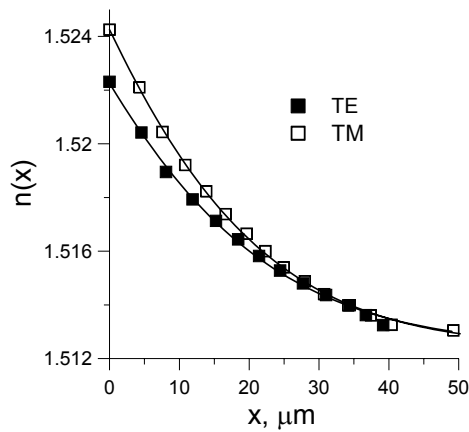

Fig.2. Profiles of refractive index for TE and TM waves in BK-7 glass, ■ - TM waves, □ - TE waves.

In Fig.3 are presented, for example, successive sequences of recorded mode field interference images for gradient index MMI section made by $\text{K}^+ - \text{Na}^+$ ion exchange for the window width 60 μm . The input field

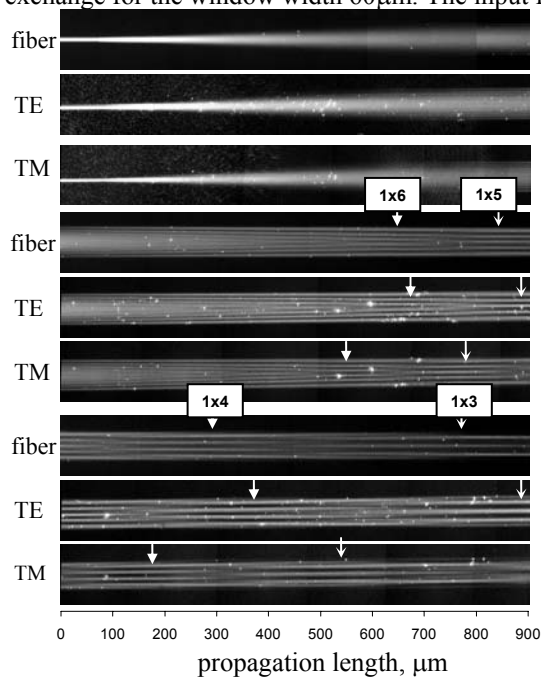

Fig.3 The successive sequences of recorded mode field interference images for MMI section of the width 60 μm symmetrically excited (a)

coming out from single-mode waveguide extends as a result of diffraction, achieving waveguide boundaries. Then, during successive reflections, the field matches to the mode structure and next interference patterns evolution along the propagation length is observed.

Section is symmetrically excited and the effects of symmetric interference are observed. Distinctly visible are 1x6, 1x5, 1x4 and 1x3 N-fold images marked in the interference pattern. In wider section, observation of is also possible. The lengths of N-fold images depend of the polarization of guided light.

Interference images shown in Fig.4 for MMI sections of the width 60 μm excited at 1/3rd of the section width are the examples of paired interference. We can distinguish here 1x5, 1x4, and 1 x 3 N-fold images. The images are not as clear as in the case of symmetrical interference. This can be explained by the effects of polarization, particularly important for asymmetrical excitation.

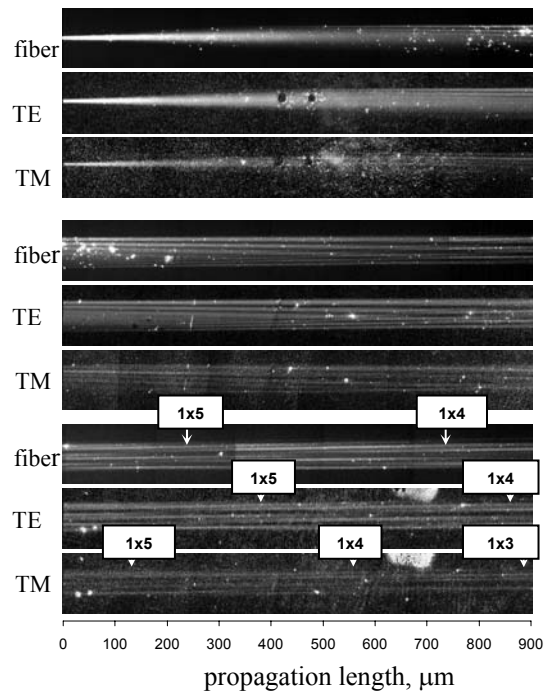

Fig.4 The successive sequences of recorded mode field interference images for MMI section of the width 60 μm , excited at 1/3rd of the section width.

Analysis of experimental results

Analysis is carry out by reference of experimental results to the existed theory for step-index waveguides. On the base of the interference patterns analysis we determine dependences which describe light propagation in MMI gradient structures.

In Fig. 5 are presented dependences of length of N-fold images on the window width for symmetric (Fig. 5a) and paired (Fig. 5b) interference. Experimental dependences are compatible with equation for step-index waveguides of the refractive index n_r and the

width W_e [1]:
$$L_z = \frac{\pi}{\beta_0 - \beta_1} \approx \frac{4n_r W_e^2}{3\lambda}$$

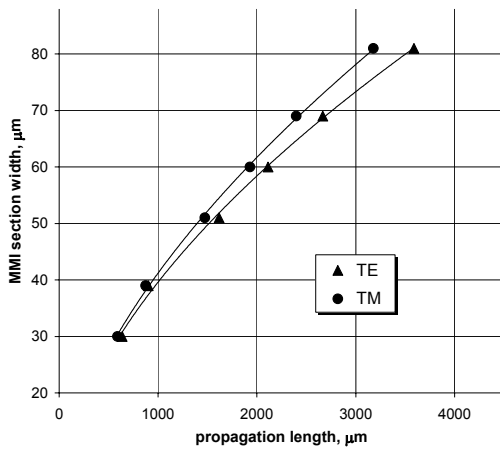

(a)

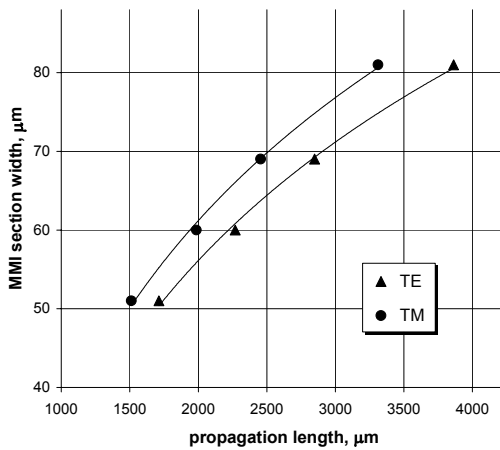

(b)

Fig.5 The dependence of length of N-fold images on the window width for MMI section made by K^+-Na^+ ion exchange; **a** - for symmetric interference, **b** - for paired interference.

which shows quadratic relation between the section width and self-imaging distance. On the base of the theory for step-index waveguides it is possible to predict the propagation lengths on which N-fold images should appear. Experimental results are compared with BPM simulations. Fig.6 shows comparison of experimental results with BPM simulations for MMI section of window width $60\ \mu\text{m}$ for symmetric (Fig. 6a) and paired (Fig. 6b) interference. In both cases the propagation length for N-fold images decrease in comparison to numerical predictions, together with increase of the propagation distance. It can be noticed that the effect is bigger for TM polarization. The deviations can be probably explained by stresses. Participation of stresses in refractive index formation is important – in BK-7 glass it is 30% for TE and 40% for TM waves of the refractive index change [5]. Stresses depend on the time of the process and geometry of the waveguide. Therefore results obtained for strip waveguides

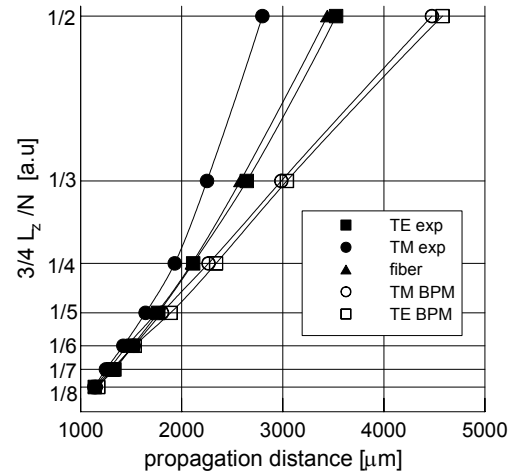

(a)

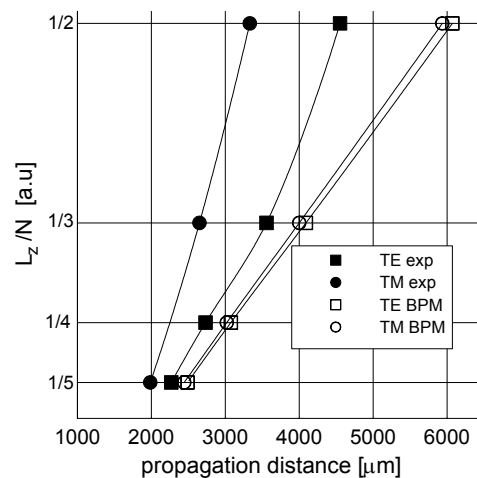

(b)

Fig.6 The comparison between experimental and theoretical dependences of lengths of N-fold images on propagation length; MMI section of the width $60\ \mu\text{m}$, (a) – symmetric interference, (b) – paired interference.

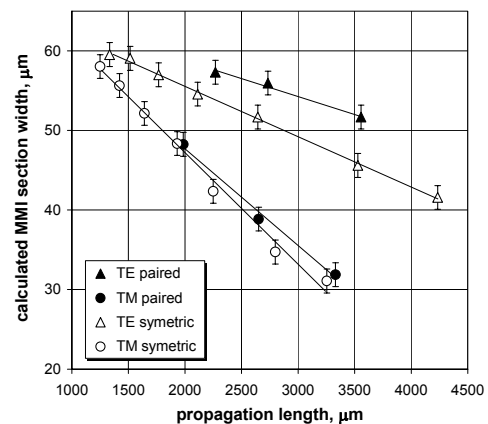

Fig.7 The dependence of calculated MMI section width on the propagation length for MMI section of the width $60\ \mu\text{m}$.

produced in the time of 1h can differ from which determine self-imaging effects. numerical simulations based on the parameters obtained for the 1-D process in the time of 165h. It could be a reason of different

than quadratic dependence of propagation constants on mode number, which decide on self-imaging phenomena.

According to the theory for step-index waveguides, MMI section width can be determine from the transversal distance between images in each particular N-fold interference pattern. In Fig. 7 are presented dependences of calculated MMI section widths on propagation length. As we can see the calculated MMI section width decrease with the increasing of the propagation distance for both polarizations. The observed decrease of the transversal distance between images is stronger for TM modes. It is similar situation as in the case of the reducing of propagation lengths for N-fold images (Fig. 6).

Conclusions

In the paper experimental investigations of MMI structures produced by K^+ - Na^+ ion-exchange are carried out. Investigations concern self-imaging phenomena of the input field for symmetrical and paired interference in dependence on polarization of guided light.

It can be confirmed that propagation length for N-fold image for symmetric and paired interference depends on MMI section width similarly as in the theory for step-index waveguides.

The propagation length for N-fold images decrease in comparison to numerical predictions, together with increase of the propagation distance. We also observe the decrease of the transversal distance between N-fold images of the input field. These effects results probably from stresses which are important for K^+ - Na^+ ion exchange.

Literature

- [1] L.B. Soldano, E.C.M Pennings, *J.Lightwave Technol.*, LT-13 , 1995 , pp.615-627
- [2] S.Das,D.Geraghty, S.Honkanen, N.Peyghambarian, *Proc. SPIE* **3936** (2000), 239.
- [3] M. Błahut, P.Karasiński, D.Kasprzak, R.Rogoziński, *Opt. Comm.* **214** (2002), 47.
- [4] M. Błahut, A.Opilski, R.Rogoziński, *Optica Applicata*, v.22, No.3-4, pp.161-169, (1992)
- [5] A. Brandenburg A., *IEEE J. Lightwave Technol.*, vol.LT-4, No. 10, pp. 1580-1592 (1986).