

All-Optical 3R Regenerator Applying Compact Semiconductors for Clock Recovery and Decision

J. Slovak, C. Bornholdt, B. Sartorius, M. Möhrle, H. P. Nolting
Fraunhofer-Institut für Nachrichtentechnik, Heinrich-Hertz-Institut, Einsteinufer 37,
D-10587 Berlin, Germany
slovak@hhi.de

All-optical 3R regeneration is performed using a dc-operated self-pulsating DFB laser (0.8 mm) for optical clock recovery and an SOA (1.5 mm) for decision. The assembled regenerator uses the novel Alternating Data Clock (ADC) scheme. An excellent regeneration performance is demonstrated at 10 Gbit/s.

Keywords: all-optical 3R regeneration, optical clock recovery, self-pulsating laser, semiconductor optical amplifier, cross gain modulation.

Introduction

All-optical 3R signal regeneration (Re-amplification, Re-timing, Re-shaping) is a key function for future transparent networks with optical cross-connects. Compact and cost effective solutions are needed because all WDM channels have to be regenerated individually. In this paper we apply a self-pulsating DFB laser for optical clock recovery and a semiconductor optical amplifier (SOA) for the decision stage. The assembled 3R regenerator, which use the novel ADC architecture [1] offers a very advantageous combination of signal regeneration and λ -conversion. The ADC regenerator equipped with an all-optical clock is investigated for the first time.

This paper begins with an overview of the assembled 3R regenerator. Next the self-pulsating DFB laser for optical clock is presented and its locking and jitter characteristics are demonstrated. The operation of SOA as decision stage in ADC-scheme is described. Finally the regenerative performance of the complete ADC-3R regenerator is investigated.

Experimental set-up of the ADC-3R regenerator

The scheme of regenerator and experimental set-up is shown in Fig. 1. A 10 Gbit/s RZ PRBS $2^{31}-1$ data signal at 1555 nm is generated and subsequently degraded. A split off part of the signal is injected into the self-pulsating laser for all-optical clock recovery. The clock emits a 10 GHz stable pulse stream at 1563 nm. Data and clock signal are delayed by half a bit, balanced in power and combined. The combined ADC-signal is injected into the SOA used for decision. A CW signal at 1548 nm is also launched into the SOA. The information of the ADC-signal is transformed by cross gain modulation (XGM) onto the CW wavelength. The CW wavelength is filtered out and the quality of the according (regenerated) signal is analysed using a sampling oscilloscope.

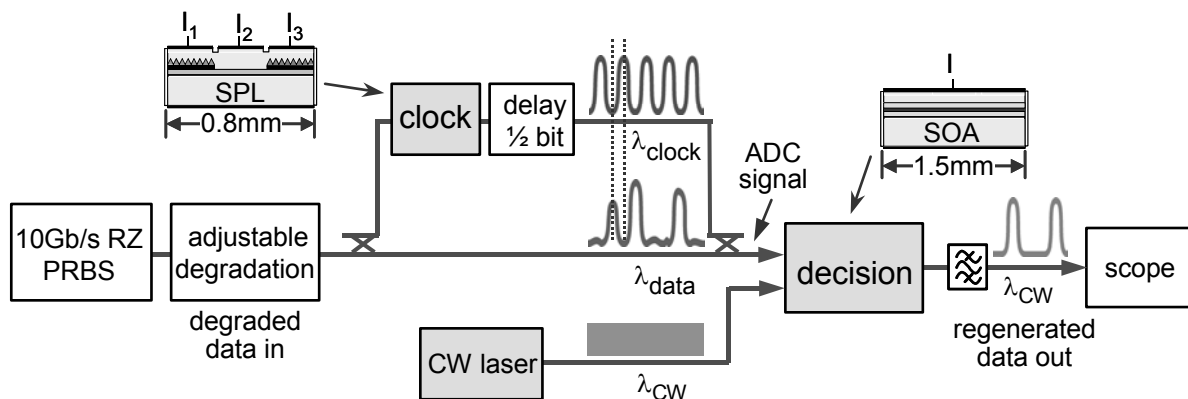

Fig. 1: Experimental set-up of the ADC-3R regenerator

Self pulsating laser for optical clock recovery

The self-pulsating laser (SPL) is a three-section InGaAsP/InP ridge waveguide device (Fig. 2a). It consists of two DFB sections (each of 250 μm length) and one integrated phase tuning section (300 μm long) /2/. The first DFB section is pumped above threshold resulting in single mode lasing operation. The second DFB section is operated close to transparency and acts as a dispersive reflector (Fig.2b). The correlation of lasing wavelength with a steep slope in the spectral reflectivity of the reflector generates self-pulsations characterised by dispersive Q-switching (DQS) /3/. Due to the chirp a rising laser pulse shifts to longer wavelengths. This leads to a decreasing feedback of the dispersive reflector. As a consequence the SPL switches itself off after emitting a short pulse and switches on again after a short time. The selection of the lasing mode and its tuning to the negative reflector slope of the stopband is done by adjusting the current in the phase section.

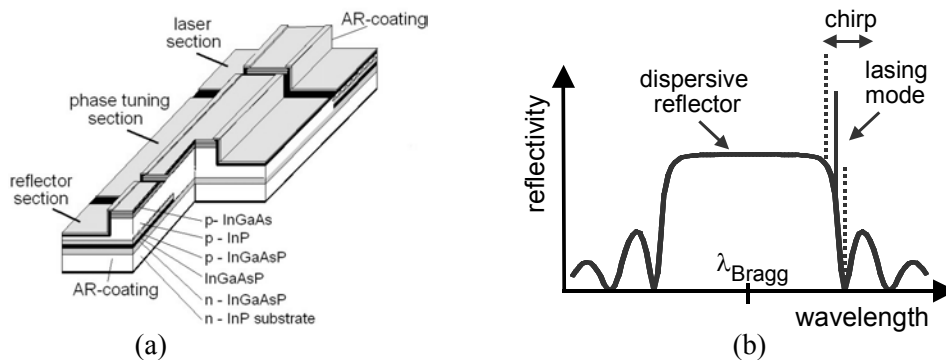

Fig. 2: Three-section self-pulsating laser (a) and the reflectivity spectrum of a DFB grating operated at transparency (b)

The repetition rate of the self-pulsations can be tuned continuously over a wide frequency range via the operating currents (2 GHz – 26 GHz). In our experiment, the frequency is adjusted close to 10 GHz (free running RF spectrum in Fig. 3b). The self-pulsation synchronises to the 10 Gbit/s RZ PRBS $2^{31}-1$ data signal that is injected into the clock module (Fig 3a). Locking of the self-pulsation can be detected by a shift of the frequency to the data rate and a narrowing of the RF-line (Fig. 3b). The locking performance of the SPL is investigated using a sampling oscilloscope. Fig. 4a shows an ideal RZ data signal (upper trace, jitter: 2.8 ps), which is injected into the DQS-clock. A stable 10 GHz pulse stream (lower trace, jitter: 1.9 ps) of the extracted clock signal can be observed. Next, the data signal is strongly degraded by additional amplitude fluctuations and timing jitter (Fig. 4b upper trace, jitter: 9.1 ps). Also in this case pattern free clock pulses with significantly reduced jitter are detected on the clock output (Fig. 4b lower trace, jitter: 3.2 ps). Thus, an excellent retiming function of the DQS-clock is verified. Please note that for any regenerator the quality of the output signal is determined mainly by the quality of the clock pulses.

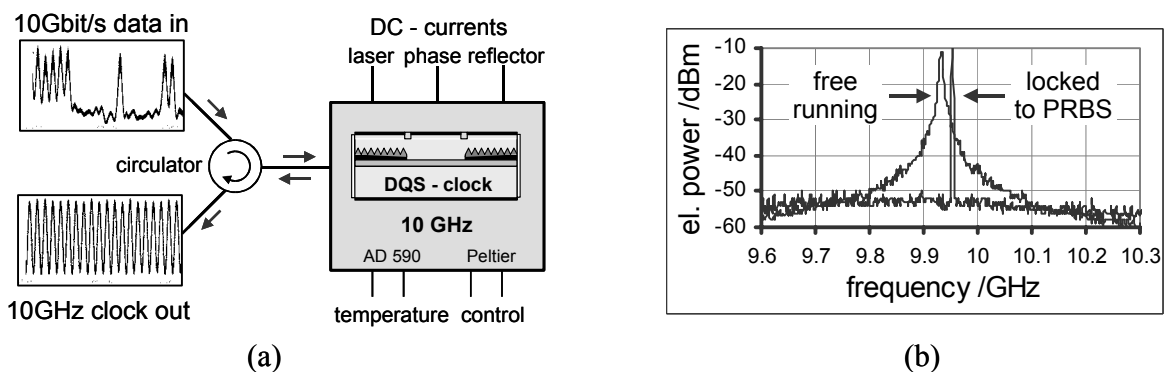

Fig. 3: Locking principle (a) and RF spectrum (b) of the self-pulsating laser

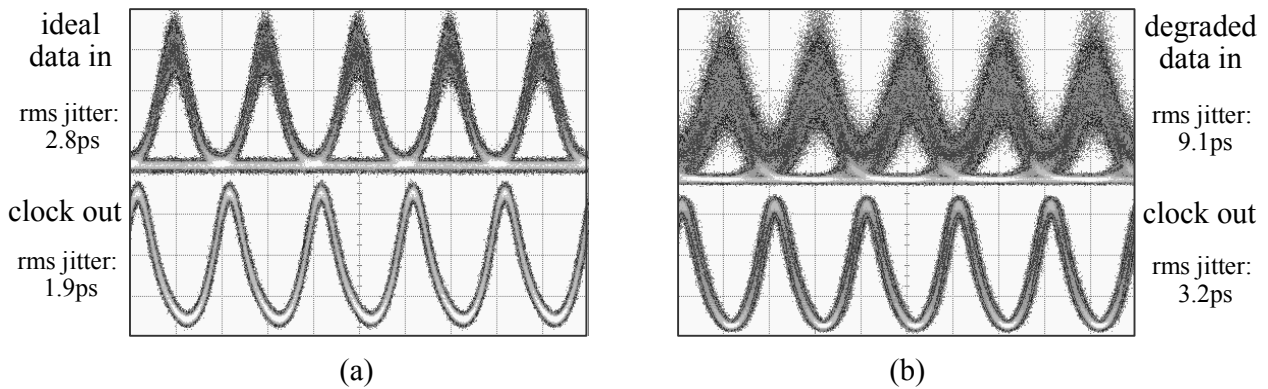

Fig. 4: 10 Gbit/s RZ PRBS ideal (a) and degraded data (b) on SPL input and the recovered clock

Wavelength converting decision using an SOA in the ADC-scheme

A 1.5 mm-long semiconductor optical amplifier (SOA) is applied for wavelength converting decision function. The SOA is polarisation insensitive with a gain peak at 1570 nm. Cross gain modulation (XGM) is used to transfer the information of the combined ADC-signal to the CW wavelength. It is well known that XGM relies on inter-band recombinations, so the modulation bandwidth is determined by the carrier dynamics [4]. Conventional XGM λ -conversion of an RZ data signal at 10 Gbit/s is thus characterised by a slow recovery time of the SOA (Fig. 5a), resulting in pattern effects and degradation of the extinction ratio.

The ADC-scheme overcomes this drawback. As mentioned above, the ADC-signal consists of a combined data and clock signal delayed by half a bit and balanced in power. The power level of the ADC signal remains constant if only “1” bits are transmitted and drops down between two adjacent clock pulses if a “0” bit is presented [1]. The resulting converted ADC signal has RZ format and is inverted in logic, the “1” bits appear as “0” and vice versa. The sharp pulses with stable amplitude demonstrate the speed improvement of the SOA by operation in the ADC scheme. The pulse shape and the timing of the new signal is determined by the clock pulses and is independent of the quality of the data signal.

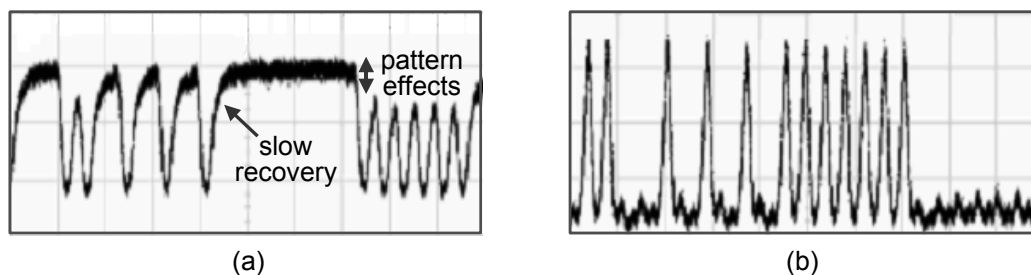

Fig. 5: Conventional XGM at 10 Gbit/s with slow recovery time (a) and XGM in ADC-scheme with enhanced speed potential (b)

Signal regeneration with ADC-3R

Finally the regenerative performance of the complete all-optical 3R regenerator is investigated by eye diagrams using a sampling oscilloscope. First an ideal 10 Gbit/s RZ signal is launched into the regenerator (Fig. 6a upper trace). The data signal on the regenerator output shows no significant difference (Fig. 6a lower trace). The timing jitter remains identical for both signals. Next a supplementary degradation unit is used to add amplitude fluctuations and timing jitter to the input data signal. The signal obtained behind this unit can be seen in Fig. 6b (upper trace). The according

output signal is shown in the lower trace of Fig. 6b. Comparing input and output in this case one can notice the significantly improved eye opening obtained by the regenerator. The amplitude and timing stability of the regenerated output pulses is only marginally affected by the strong amplitude fluctuations and the timing jitter of the degraded input signal. The excellent regenerative function, even for strongly degraded input signals, demonstrates the very good performance of our all-optical ADC-3R regenerator.

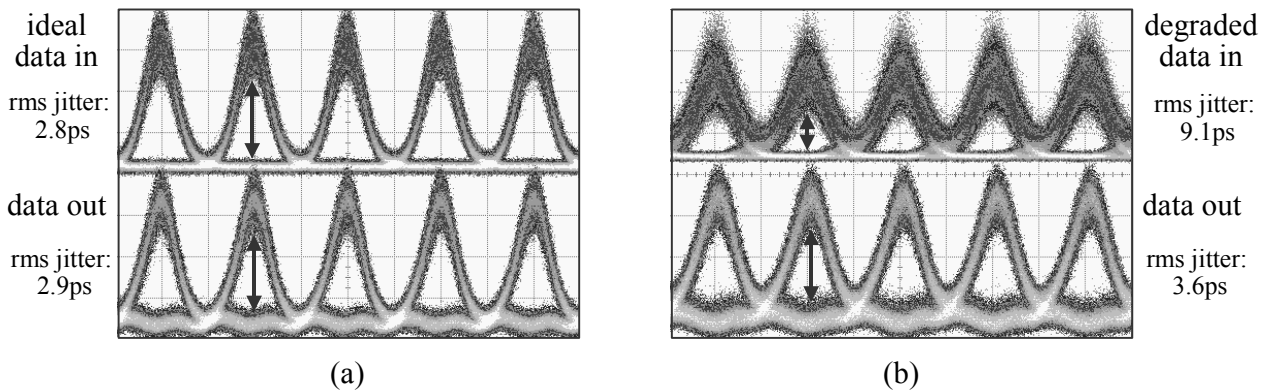

Fig. 6: 10 Gbit/s RZ PRBS ideal (a) and degraded data signal (b) on ADC-3R input and the regenerated output signal

Summary

An all-optical 3R regenerator is assembled applying compact and cost effective semiconductor devices for clock recovery and decision. The novel ADC-3R architecture equipped with an optical clock recovery is tested for the first time. The optical clock recovery is based on a self-pulsating DFB laser and delivers a low jitter pulse trace even in the case of strongly jittered input signals. The speed and performance of XGM in the SOA used for decision and wavelength conversion is significantly enhanced due to the ADC operation scheme. The performance of the complete ADC-3R regenerator is investigated at 10 Gbit/s using a sampling oscilloscope. Output pulses stable in amplitude and time and a significantly improved eye opening demonstrate the excellent function of the semiconductor based ADC-3R regenerator.

References

- [1] B. Sartorius et al.: "Novel 3R Regenerator Architecture with Wavelength Flexible Output", ECOC 2002, Copenhagen, paper No. 06.3.3, (2002).
- [2] B. Sartorius et al.: "All-optical clock recovery module based on self-pulsating DFB laser", Electronics Lett., 20th August 1998, Vol. 36, No. 17.
- [3] B. Sartorius et al.: "Dispersive Self-Q-Switching in Self-Pulsating DFB Lasers", IEEE of Quantum Electronics, Vol. 33, No. 2, February 1997.
- [4] T. Durhuus et al.: "All-Optical Wavelength Conversion by Semiconductor Optical Amplifiers", Journal of Lightwave Technology, Vol. 14, No.6, June 1996.